

# CARGO CHARGED, PROFIT SUPERCHARGED!



195 KM\* - INDUSTRY'S BEST MILEAGE

**ENERGIE<sup>2</sup>**

# DOUBLE BATTERY, DOUBLE RANGE!

Industry's First Electric Three-Wheeler Powered by Double Battery Pack.

- Advanced Battery Cooling Technology
- Oil-Immersed Lithium-Ion Battery Provides Superior Protection Against Overheating.



Industry's  
Best Mileage

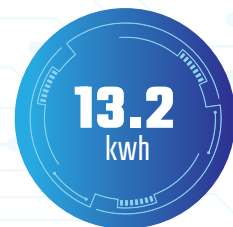

Industry's Largest  
Battery Capacity



YEAR OF BATTERY WARRANTY



# ENGINEERED IN EUROPE BUILT IN INDIA

Charge from Delta Q



Thermalised Battery Pack  
for Extreme Weather  
Conditions



Motor Drive  
for Valeo



Advanced  
Telematics



Connectors  
from Amphenol





# ATUL INTELLIGENT SYSTEM (AIS)

POWERED BY AI



## Real-Time Monitoring

Real-time monitoring of vehicles and their systems to provide on-demand insights and updates at all times.



## Remote Visualization

Remote visualization of various parameters such as SOC, speed, alarms, and route history.



## Preventive Maintenance

Preventive maintenance through real-time diagnosis and over-the-air monitoring of the vehicle.



## 24x7 Customer Support

Platform support for drivers and fleet operators covering vehicle service and warranty, workshops, maintenance, vehicle finance companies, and charging infrastructure.



## Fleet Monitoring

A fleet management app that allows operators to track and monitor fleet activity virtually, providing real-time updates on vehicle health, charge status, and location.

POWER-PACKED PERFORMANCE!

# 500 KG PAYLOAD

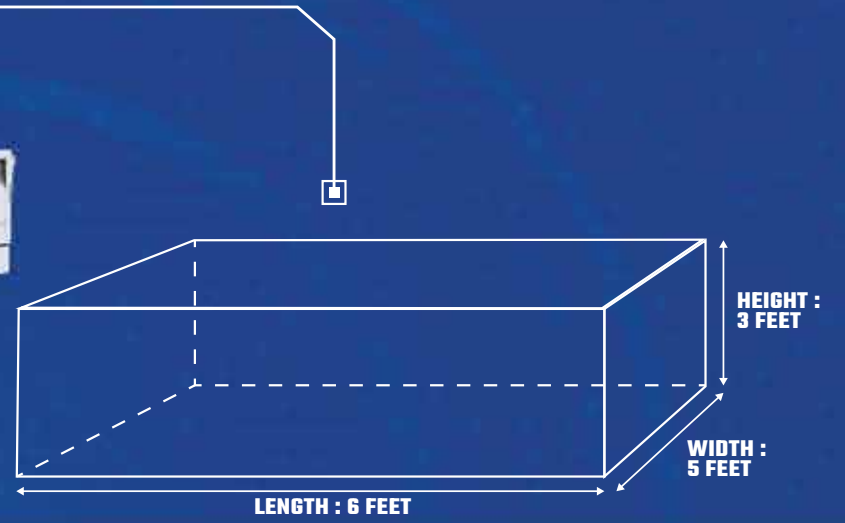

# STRONG CHASSIS



## SOLID METALLIC BUILD



## WIDER DRIVER SPACE



## QUICK CHARGING 0 TO 80% IN JUST 4 HOURS



## ROBUST SUSPENSION





# BIG RADIAL TYRES

- Large & wider tyre size : 135/70 R12 4PR 69S (MRF), The big radial tubeless tyre makes repairs easier.
- Wider tyre for better stability & radial tyre with low friction, providing an excellent driving experience.
- An easy, comfortable, and vibration-free ride for both the driver and passenger.

# POLYCHROME INSTRUMENT CLUSTER



- Colourful Digital Instrument Cluster
- Precise Indication of Defined Parameters and Signals
- Aesthetically Designed to Display all Important Indications

# RELIABLE IN EVERY SEASON



IP67\* Rated Components: Battery Pack, Motor, Charger, Connectors

\*IP67 is an International Protection Marking (IP) rating that indicates a product is dust tight and can withstand water immersion for up to 30 minutes at a depth of 1 meter.





# POWER OF SAVINGS IN EVERY JOURNEY

SAVE UP TO **5** LAKH IN 5 YEARS!



# DEPENDABLE IN EVERY JOURNEY

Our commitment to your journey doesn't end with your purchase.

For any unexpected situations, we're here to assist you around the clock.

Just Dial **022 - 67347495** for Roadside Assistance Anytime, Anywhere.



**Roadside Assistance - 24X7**



# DEPENDABLE IN EVERY JOURNEY

Our commitment to your journey doesn't end with your purchase.

For any unexpected situations,  
we're here to assist you around the clock.

  
 **Just Dial**  
**022 - 67347495**  
for Roadside Assistance  
Anytime, Anywhere.



**Roadside Assistance - 24X7**



## TECHNICAL SPECIFICATIONS

VARIANTS	ENERGIE	ENERGIE <sup>2</sup>
	Performance	
Payload	500	500
Certified Range	107	195
Maximum Speed	45	45
Charging Time (0 to 80%)	4-5hrs*	6-7hrs*
On Board Charger	1.5KW	2.2kw
	Battery Power Pack	
Battery Type	Lithium-ion	Lithium-Ion
Capacity	6.6 kWh	13.2 kWh
	Specification	
Seating Capacity	Driver	Driver
Steering System	Handle Bar	Handle Bar
Ground Clearance	215	215
Wheelbase	2125	2125
Turning Radius	3.50 m	3.50 m
Gradeability	12%	12%
Overall Length	3350	3350
Overall Width	1510	1510
Overall Height	1700	1700
Gross Vehicle Weight	995	995
Load Capacity	500Kg	500Kg
Tyres	4.50-10	4.50-10

VARIANTS	ENERGIE	ENERGIE <sup>2</sup>
	Motor	
Type	AC Synchronous	
Peak Power	9.92 kW	
Peak Torque	44 Nm	
	Brake System	
Front & Rear	Hydraulic	
	Suspension System	
Front	Anti Dive Leading Link With Dual Action Telescopic Hydraulic Shock Absorber Helical Compression Coil Spring	
Rear	Trailing Arm, Helical Compression With Coil Spring Telescopic Shock Absorber	
	Technology	
Battery Thermal Management System	Active + Passive Cooling	
Regenerative Braking	Efficient Energy Recovery	
Vehicle Telemetry System	Atul Intelligence (AI) Platform	
IP 67 Rated Components	Motor, PDU, VCU, Battery & All Connectors	

## ATUL AUTO LIMITED

Marketing Head Office: 406, Baleshwar Square, Opp. Iscon Mall, S.G. Highway, Ahmedabad - 380015, Gujarat - India. | Customer Care: 89 888 70 999 | Email: [marketing@atulauto.co.in](mailto:marketing@atulauto.co.in)

[www.atulauto.co.in](http://www.atulauto.co.in) [f atulautold](https://www.facebook.com/atulautold) [@ atul\\_auto ltd](https://www.instagram.com/atul_auto ltd)

Authorised Dealer